

## Transient Voltage Suppressors (TVS) Data Sheet

### Features

- For surface mounted applications in order to optimize board space
- Low profile package
- Glass passivated junction
- Low inductance
- Excellent clamping capability
- 600W peak pulse power capability at 10/1000µs waveform, repetition rate (duty cycle): 0.01%
- Fast response time
- Typical  $I_R$  less than 1µA above 10V
- High Temperature soldering: 260°C/10 seconds at terminals
- Plastic package has underwriters laboratory flammability 94V-0
- Meets MSL level 1, per J-STD-020
- AEC-Q101 qualified (Automotive grade with suffix "Q".)
- Expsemi electronics



### Mechanical Data

- Case: JEDEC DO-214AC. Molded plastic over glass passivated junction
- Terminal: Solder plated, solderable per MIL-STD-750, Method 2026
- Polarity: Color band denotes cathode except bi-directional models

### Applications

- AC/DC power supply
- I/O interface
- Low frequency signal transmission line

### Maximum Ratings and Characteristics

Ratings at 25°C ambient temperature unless otherwise specified.

Rating	Symbol	Value	Units
Peak pulse power dissipation at 10/1000µs waveform (Note1, Note2, Fig.1)	$P_{PPM}$	Minimum 600	Watts
Peak pulse current of at 10/1000µs waveform (Note 1, Fig.3)	$I_{PPM}$	See Table	Amps
Steady state power dissipation at $T_A=50^\circ\text{C}$ (Fig.5)	$P_D$	3.3	Watts
Peak forward surge current, 8.3ms single half sine-wave superimposed on rated load, (JEDEC Method) (Note3, Fig.6)	$I_{FSM}$	40	Amps
Operating junction and Storage Temperature Range.	$T_J, T_{STG}$	-65 to +150	°C
Typical thermal resistance junction to lead	$R_{\theta JL}$	30	°C/W
Typical thermal resistance junction to ambient	$R_{\theta JA}$	120	°C/W

Notes: 1. Non-repetitive current pulse, per Fig.3 and derated above  $T_A=25^\circ\text{C}$  per Fig.2.

2. Mounted on 5.0mm×5.0mm (0.03mm thick) copper pads to each terminal.

3. 8.3ms single half sine-wave, or equivalent square wave, duty cycle=4 pulses per minutes maximum.

**Electrical Characteristics (T<sub>A</sub>=25°C)**

Part Number		Device Marking Code		Reverse Stand-Off Voltage	Breakdown Voltage @I <sub>T</sub>	Test Current	Maximum Clamping Voltage @I <sub>PP</sub>	Peak Pulse Current	Reverse Leakage @V <sub>RWM</sub>
Unidirectional	Bidirectional	UNI	BI	V <sub>RWM</sub> (V)	V <sub>BR</sub> (V)	I <sub>T</sub> (mA)	V <sub>C</sub> (V)	I <sub>PP</sub> (A)	I <sub>R</sub> (μA)
SMA6L5.0A	SMA6L5.0CA	6AE	6WE	5.0	6.40~7.00	10	9.2	65.3	800
SMA6L6.0A	SMA6L6.0CA	6AG	6WG	6.0	6.67~7.37	10	10.3	58.3	800
SMA6L6.5A	SMA6L6.5CA	6AK	6WK	6.5	7.22~7.98	10	11.2	53.6	500
SMA6L7.0A	SMA6L7.0CA	6AM	6WM	7.0	7.78~8.60	10	12.0	50	200
SMA6L7.5A	SMA6L7.5CA	6AP	6WP	7.5	8.33~9.21	1	12.9	46.6	100
SMA6L8.0A	SMA6L8.0CA	6AR	6WR	8.0	8.89~9.83	1	13.6	44.2	50
SMA6L8.5A	SMA6L8.5CA	6AT	6WT	8.5	9.44~10.40	1	14.4	41.7	20
SMA6L9.0A	SMA6L9.0CA	6AV	6WV	9.0	10.00~11.10	1	15.4	39	10
SMA6L10A	SMA6L10CA	6AX	6WX	10.0	11.10~12.30	1	17.0	35.3	5
SMA6L11A	SMA6L11CA	6AZ	6WZ	11.0	12.20~13.50	1	18.2	33	1
SMA6L12A	SMA6L12CA	6BE	6XE	12.0	13.30~14.70	1	19.9	30.2	1
SMA6L13A	SMA6L13CA	6BG	6XG	13.0	14.40~15.90	1	21.5	28	1
SMA6L14A	SMA6L14CA	6BK	6XK	14.0	15.60~17.20	1	23.2	25.9	1
SMA6L15A	SMA6L15CA	6BM	6XM	15.0	16.70~18.50	1	24.4	24.6	1
SMA6L16A	SMA6L16CA	6BP	6XP	16.0	17.80~19.70	1	26.0	23.1	1
SMA6L17A	SMA6L17CA	6BR	6XR	17.0	18.90~20.90	1	27.6	21.8	1
SMA6L18A	SMA6L18CA	6BT	6XT	18.0	20.00~22.10	1	29.2	20.6	1
SMA6L20A	SMA6L20CA	6BV	6XV	20.0	22.20~24.50	1	32.4	18.6	1
SMA6L22A	SMA6L22CA	6BX	6XX	22.0	24.40~26.90	1	35.5	17.0	1
SMA6L24A	SMA6L24CA	6BZ	6XZ	24.0	26.70~29.50	1	38.9	15.5	1
SMA6L26A	SMA6L26CA	6CE	6YE	26.0	28.90~31.90	1	42.1	14.3	1
SMA6L28A	SMA6L28CA	6CG	6YG	28.0	31.10~34.40	1	45.4	13.3	1
SMA6L30A	SMA6L30CA	6CK	6YK	30.0	33.30~36.80	1	48.4	12.4	1
SMA6L33A	SMA6L33CA	6CM	6YM	33.0	36.70~40.60	1	53.3	11.3	1
SMA6L36A	SMA6L36CA	6CP	6YP	36.0	40.00~44.20	1	58.1	10.4	1
SMA6L40A	SMA6L40CA	6CR	6YR	40.0	44.40~49.10	1	64.5	9.3	1
SMA6L43A	SMA6L43CA	6CT	6YT	43.0	47.80~52.80	1	69.4	8.7	1
SMA6L45A	SMA6L45CA	6CV	6YV	45.0	50.00~55.30	1	72.7	8.3	1
SMA6L48A	SMA6L48CA	6CX	6YX	48.0	53.30~58.90	1	77.4	7.8	1
SMA6L51A	SMA6L51CA	6CZ	6YZ	51.0	56.70~62.70	1	82.4	7.3	1
SMA6L54A	SMA6L54CA	6RE	6ZE	54.0	60.00~66.30	1	87.1	6.9	1
SMA6L58A	SMA6L58CA	6RG	6ZG	58.0	64.40~71.20	1	93.6	6.5	1
SMA6L60A	SMA6L60CA	6RK	6ZK	60.0	66.70~73.70	1	96.8	6.2	1
SMA6L64A	SMA6L64CA	6RM	6ZM	64.0	71.10~78.60	1	103.0	5.9	1
SMA6L70A	SMA6L70CA	6RP	6ZP	70.0	77.80~86.00	1	113.0	5.3	1
SMA6L75A	SMA6L75CA	6RR	6ZR	75.0	83.30~92.10	1	121.0	5	1
SMA6L78A	SMA6L78CA	6RT	6ZT	78.0	86.70~95.80	1	126.0	4.8	1
SMA6L85A	SMA6L85CA	6RV	6ZV	85.0	94.40~104.00	1	137.0	4.4	1
SMA6L90A	SMA6L90CA	6RX	6ZX	90.0	100.00~111.001		146.0	4.2	1
SMA6L100A	SMA6L100CA	6RZ	6ZZ	100.0	111.00~123.00	1	162.0	3.8	1

Ratings and Characteristic Curves ( $T_A=25^{\circ}\text{C}$  unless otherwise noted)

Figure 1. Peak Pulse Power Rating Curve

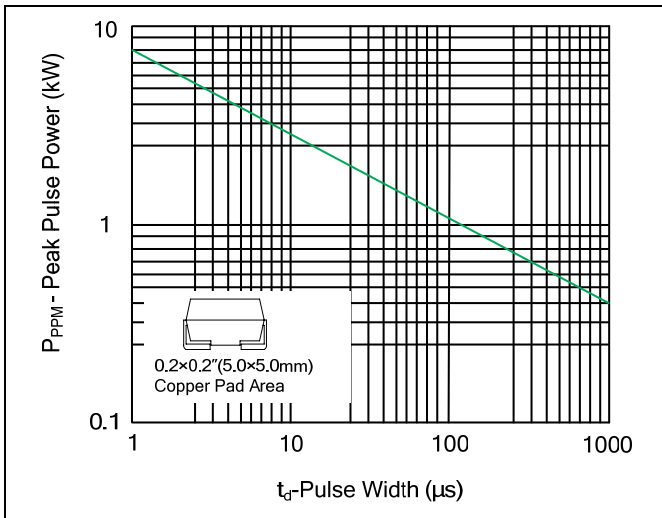

Figure 2. Pulse Derating Curve

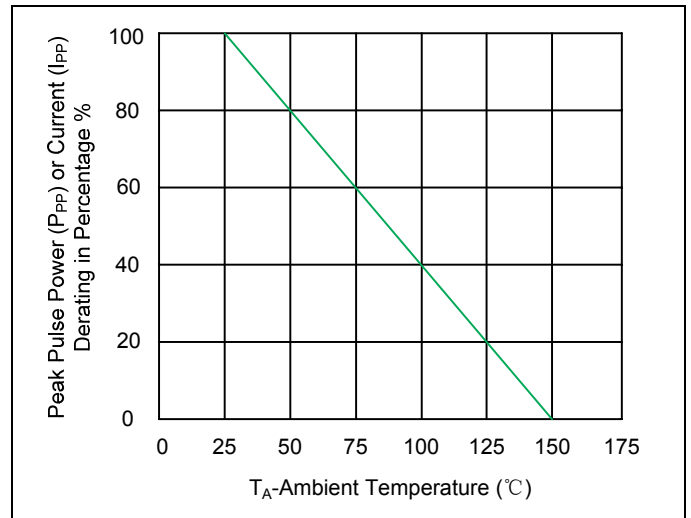

Figure 3. Pulse Waveform

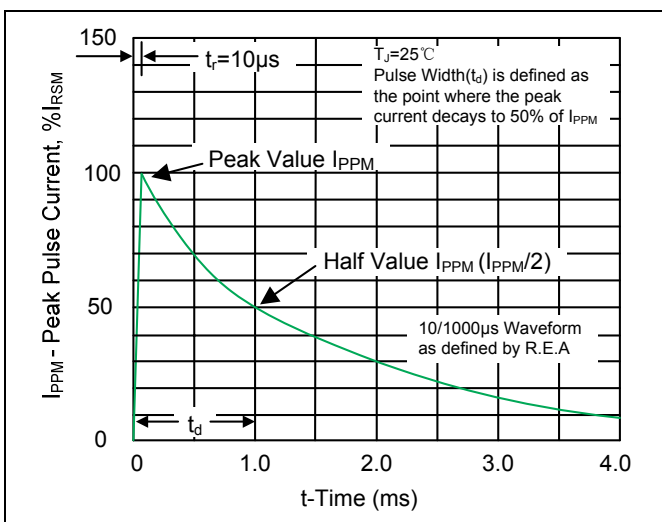

Figure 4. Typical Junction Capacitance

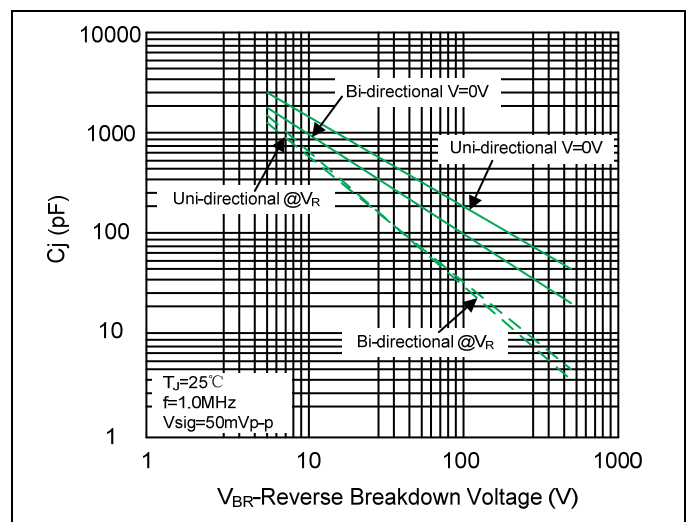

Figure 5. Steady State Power Dissipation Derating Curve

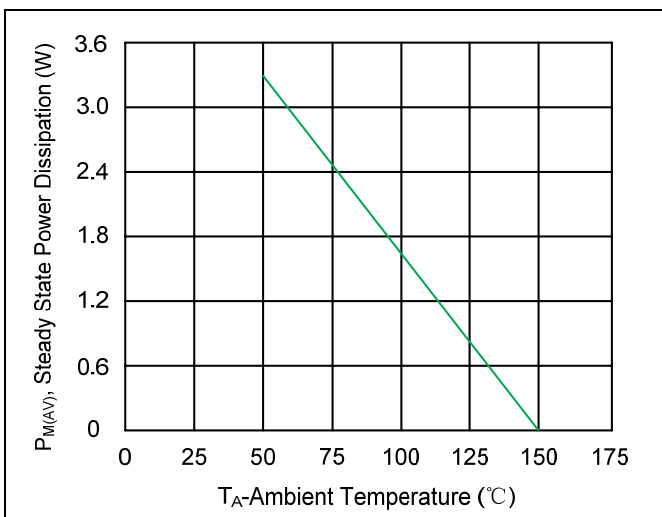
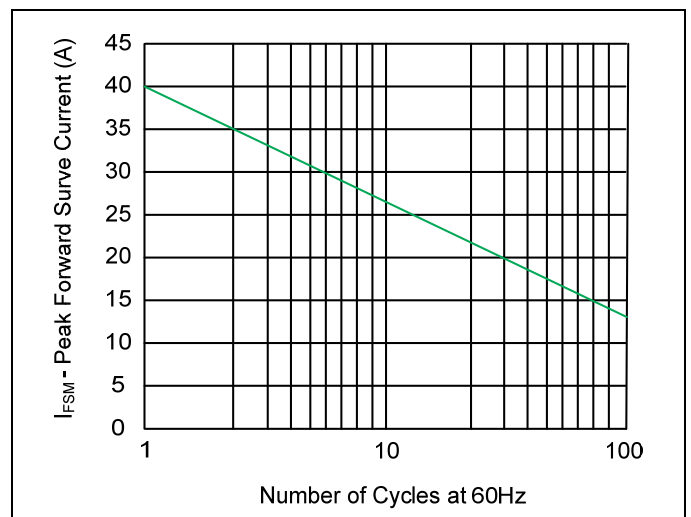

Figure 6. Maximum Non-Repetitive Forward Surge Current Uni-Directional Only



## Recommended Soldering Conditions

### Soldering Parameters

Reflow Condition		Lead-free assembly
Pre Heat	- Temperature Min ( $T_{s(min)}$ )	150°C
	- Temperature Max ( $T_{s(max)}$ )	200°C
	- Time (min to max) ( $t_s$ )	60 – 180 secs
Average ramp up rate (Liquidus Temp ( $T_A$ ) to peak)		3°C/second max
$T_{s(max)}$ to $T_A$ - Ramp-up Rate		3°C/second max
Reflow	- Temperature ( $T_A$ ) (Liquidus)	217°C
	- Time (min to max) ( $t_s$ )	60 – 150 seconds
Peak Temperature ( $T_p$ )		260 <sup>+0/-5</sup> °C
Time within 5°C of actual peak Temperature ( $t_p$ )		20 – 40 seconds
Ramp-down Rate		6°C/second max
Time 25°C to peak Temperature ( $T_p$ )		8 minutes Max.
Do not exceed		260°C

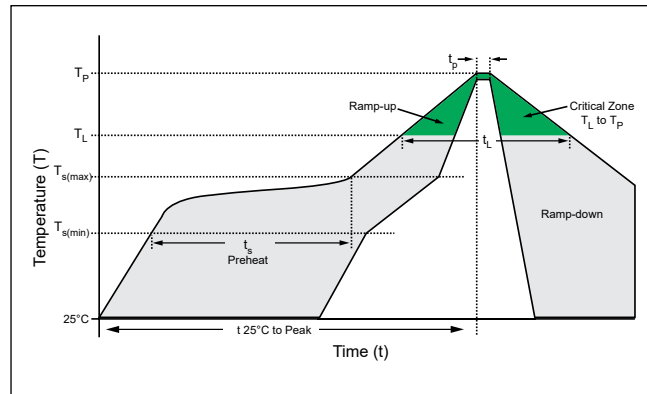

### Physical Specifications

<b>Case</b>	JEDEC DO-214AC Molded Plastic over glass passivated junction
<b>Polarity</b>	Color band denotes cathode except Bipolar
<b>Terminal</b>	Matte Tin-plated leads, Solderable per JESD22-B102

### Environmental Specifications

<b>High Temp. Storage</b>	JESD22-A103
<b>HTRB</b>	JESD22-A108
<b>Temperature Cycling</b>	JESD22-A104
<b>MSL</b>	JEDEC-J-STD-020, Level 1
<b>H3TRB</b>	JESD22-A101
<b>RSH</b>	JESD22-A111

### Dimensions

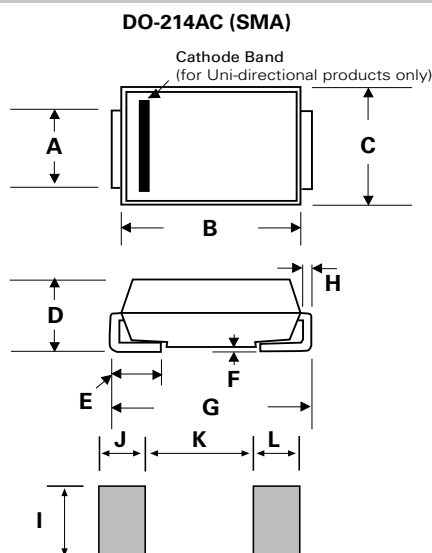

Dimensions	Inches		Millimeters	
	Min	Max	Min	Max
A	0.047	0.065	1.200	1.650
B	0.157	0.181	3.990	4.600
C	0.095	0.114	2.400	2.900
D	0.075	0.096	1.900	2.440
E	0.030	0.060	0.780	1.520
F	-	0.008	-	0.203
G	0.189	0.208	4.800	5.280
H	0.006	0.012	0.152	0.305
I	0.070	-	1.800	-
J	0.082	-	2.100	-
K	-	0.090	-	2.300
L	0.082	-	2.100	-

**Part Numbering System**

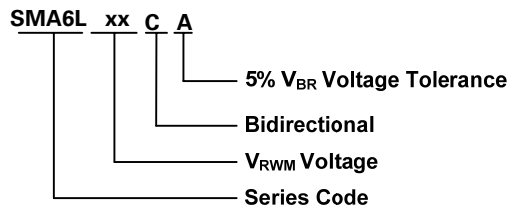

**Part Marking System**

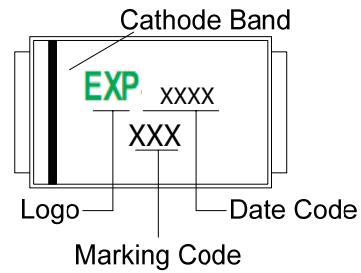

**Packaging**

Part number	Component Package	Quantity	Packaging Option	Packaging Specification
SMA6L-xxxXX	DO-214AC	5000	Tape & Reel - 12mm tape/13" reel	EIA STD RS-481

**Tape and Reel Specification**

